



X Available in 29U, 42U and 47U heights

X 1000 or 1200 mm deep

X Grey White or Black colour

X 1300 kg load capacity

X Removable base panels for cable entry

X Sliding letterbox style cable entry in roof

X Wave design mesh style front door

X Swing handle two point lock front door

X Wardrobe style double mesh rear doors

X Swing handle three point lock rear doors

X High density vertical cable management

X Supplied assembled or flat pack

### Features

- Available in 29U, 42U and 47U heights
- 1000 or 1200 mm deep
- Grey White or Black colour
- 1300 kg load capacity
- Sliding letterbox style cable entry in roof
- Heavy duty lockable casters included
- Swing handle two point lock front door
- Swing handle three point lock rear doors
- Full height front and rear adjustable 19" profiles
- Supplied assembled or flat pack
- 70% ventilation front and rear doors
- Doors open 235° / 180°
- 150mm cable tray included
- Baying kit included
- Can be bayed with or without side panels
- Jacking feet included
- Removable base panels for cable entry
- Wave design mesh style front door
- Jacking feet and casters can be fitted simultaneously
- Wardrobe style double mesh rear doors
- High density vertical cable management
- Galvanised steel 19" mouting profiles
- 19" profiles marked with U height position
- Quick release hinged doors
- Removable side panels - horizontally split on 42U and 47U

## Product Overview

The Environ SR800 is a versatile range of 800 mm wide racks fitted with a wave vented front door and double vented rear doors. Designed to accommodate a load of up to 1300 kg and available in a range of heights and depths they offer features that make them suitable for a wide range of applications in the data centre and telecommunications arenas.

## Environ SR800 Rack - Exploded View

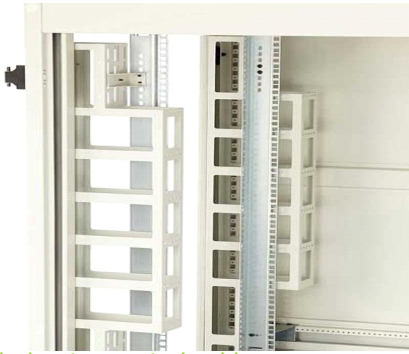

High density vertical cable management

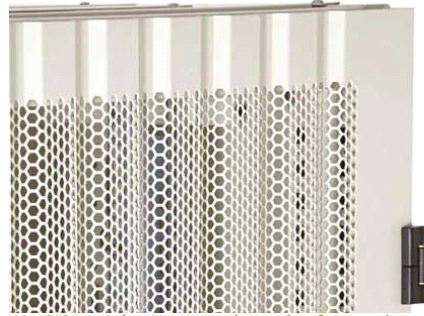

Wave design mesh style front door



Removable base panels for cable entry

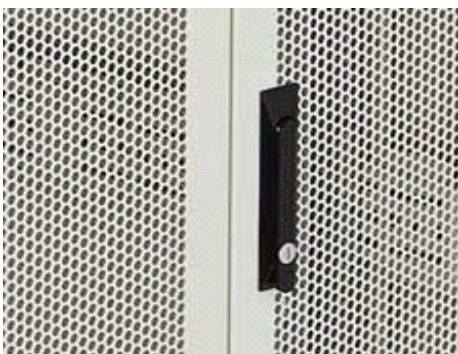
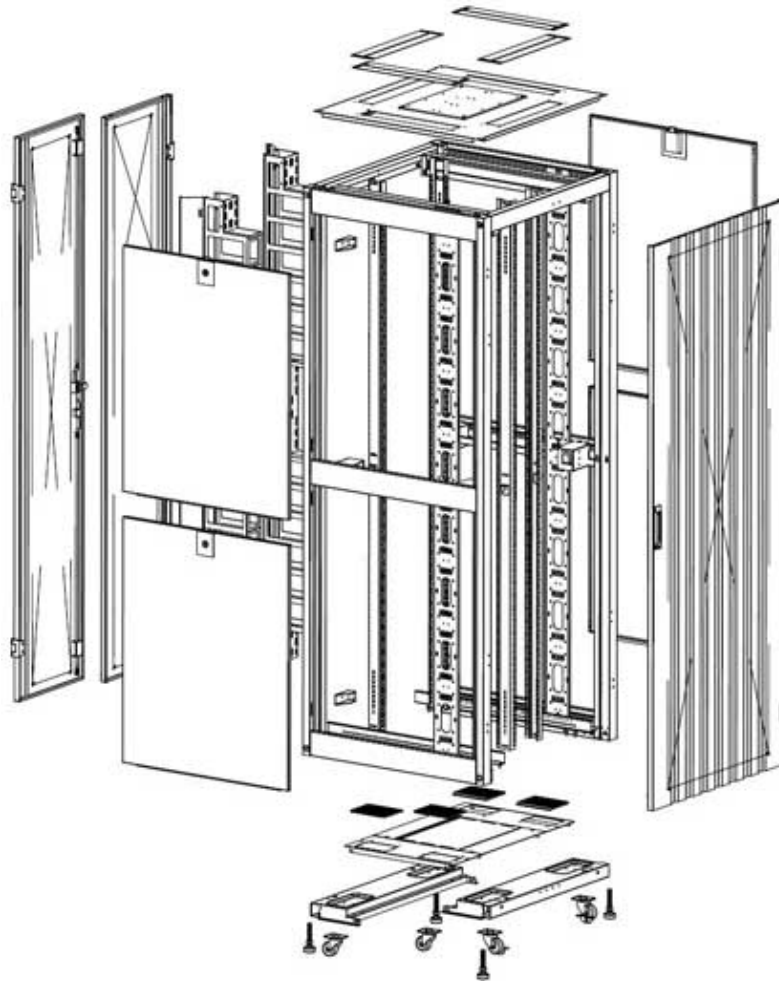

Wardrobe style double mesh rear doors



Quick release hinged side



Excel branding on the inside of the cabinet

## Environ SR800 Rack Elevation Views

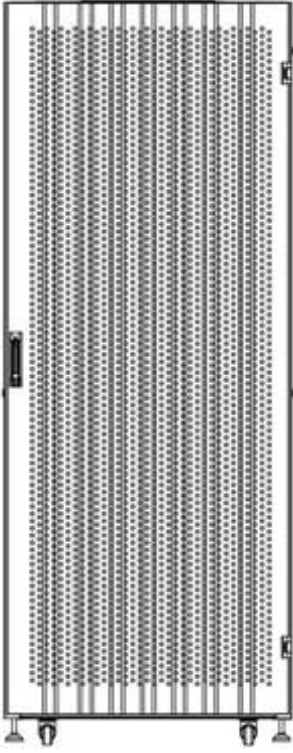

Front

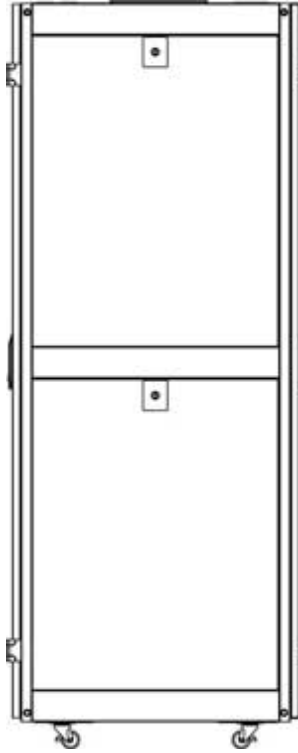

Side

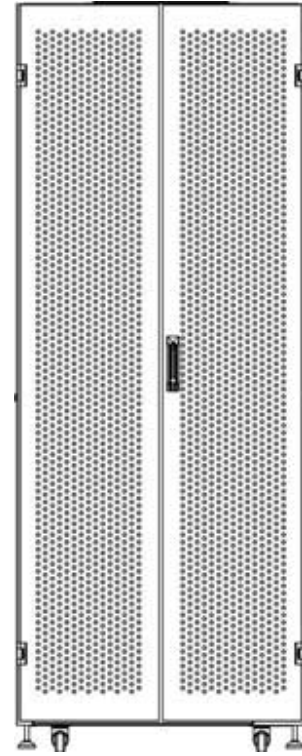

Rear

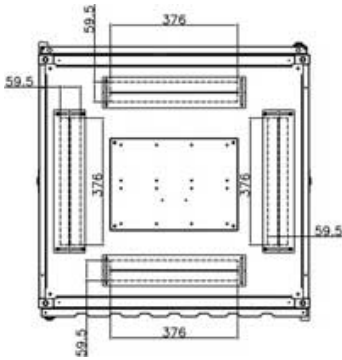

Roof

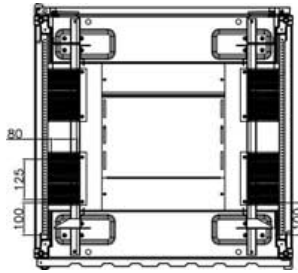

Base

### Overall Dimensions

#### Heights

29U = 1422 mm High

42U = 2000 mm High

47U = 2223 mm High

*the casters add 72 mm to the height*

#### Width

800 mm Wide

#### Depths

1000 mm Deep

1200 mm Deep



## Specification

Detail	Value
Standard	ANSI/EIA-310-E
-	IEC 60297-2
-	DIN 41494 Part 1 & 7
Material	SPCC Cold Rolled Steel
19" Rails	2.0 mm thick
Top bar	1.5 mm thick
Door, top panel and side frame	1.2 mm thick
Other	1.0 mm thick
Colour	Grey White - RAL 9002
-	Black - RAL9004
Load capacity	1300 kg (Static)
Front door lock	2 point swing handle cam lock
Rear door lock	3 point swing handle cam lock
Side panels lock	Single point barrel lock

## Part Number Information - Complete Racks

A complete rack comprises wave design mesh front door, wardrobe style mesh rear doors, steel side panels and front and rear 19" profiles, and full height vertical cable management to rear of rack.

### 1000 mm Deep Racks

Description	U Size	Width	Depth	Overall Height	Grey White	Black
Environ SR800	29U	800 mm	1000 mm	1422 mm	544-29810-WDBR-GW	544-29810-WDBR-BK
Environ SR800	42U	800 mm	1000 mm	2000 mm	544-42810-WDBR-GW	544-42810-WDBR-BK
Environ SR800	47U	800 mm	1000 mm	2223 mm	544-47810-WDBR-GW	544-47810-WDBR-BK

### 1200 mm Deep Racks

Description	U Size	Width	Depth	Overall Height	Grey White	Black
Environ SR800	29U	800 mm	1200 mm	1422 mm	544-29812-WDBR-GW	544-29812-WDBR-BK
Environ SR800	42U	800 mm	1200 mm	2000 mm	544-42812-WDBR-GW	544-42812-WDBR-BK
Environ SR800	47U	800 mm	1200 mm	2223 mm	544-47812-WDBR-GW	544-47812-WDBR-BK

Please note that the Grey White versions of the ER and SR racks will be available from April 2014 onwards.

Jacking Feet adds 20 - 80 mm to the height. Castors add 70 mm to the height.

## System Warranty

The Excel System Warranty provides a 25-year product and applications assurance of compliance with the industry performance standard appropriate to the class of cabling installed. The Excel rack range is covered by the 25 year warranty when installed as part of a complete Excel solution. The warranty may be applied for by an accredited Excel Partner who has designed, supplied and installed the said system.



### axilan

c.so santorre di santarosa 36, cuneo, Cuneo, 12100, Italia

Tel: +390171692038

Email: [info@axilan.it](mailto:info@axilan.it) Web: [www.axilan.it](http://www.axilan.it)



**AXILAN**<sup>®</sup>  
OPTICAL and COPPER WIRING

E&OE. Excel is a registered trade name of Mayflex Holdings Ltd.

[www.excel-networking.com](http://www.excel-networking.com)